

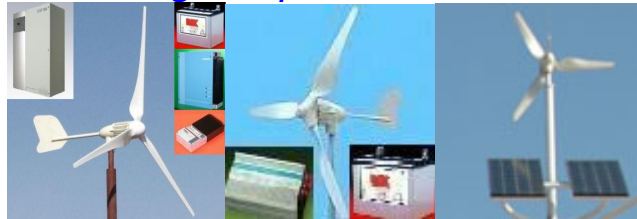

www.greenpower4less.com



WINDMAX H Series Wind Turbine

USER'S MANUAL

Windmax-H5 & Windmax-H8



Introduction

WINDMAX-H series wind turbine system is the most advanced and efficient system we build. The WINDMAX-H series is CE and ISO certified.

WINDMAX-H series wind turbine system features:

- ✓ Hybrid Solar/Wind Dual Output Capability to take advantage of both solar energy and wind energy at the same time, highly efficient.
- ✓ Features Electromagnetic speed limitation and blade over-speed braking, no problematic mechanical furling is needed. Combination of Electromagnetic braking and aerodynamic braking maximizes energy capture by extending Windmax H series turbine's operating speed range into higher speed winds and lower speed winds which are missed by the old style wind turbines.
- ✓ Patented aerofoil blade design makes the system run much more efficient, rotor blades are made with the latest advanced thermoplastic engineering and precision injection molding technology.
- ✓ Innovative maintenance-free two-moving-part system design. Windmax H series adopted Innovative over-speed control so it improves the reliability by eliminating the moving parts for mechanical over-speed protection and minimizing the moving parts to only two.
- ✓ The blades have exceptional consistency and aerodynamic outline with a mass distribution that ensures the rotors operate with nearly no noise and minimal vibration.
- ✓ Wind/Solar hybrid controller to work with both wind turbine and solar panels.
- ✓ Low Start-up and cut-in speed; begin producing power at 5.2 mph. very low start-up/cut-in wind speed and a high coefficient of productivity and is specially designed to prevent the blades from feathering post stall.
- ✓ The generator is built using high-performance permanent magnets, so the alternator is compact and light weight with a high power generating efficiency. The unique winding and multi pole design reduces the start-up torque of the alternator that assures the WINDMAX-H can generate electricity at low wind speed.
- ✓ Generator housing is made with precision cast technology from high strength aluminum to assure a high quality finish. It is designed for various working conditions such as severe climate, sand and salt corrosive environments and marine usage.
- ✓ Exquisite set with unmatched power generating performance. It is a great green power source for the modern living environment.

The system is easy to install; however, it is important that you read this manual thoroughly prior to installation to assure proper performance and safety.

1. Package Contents

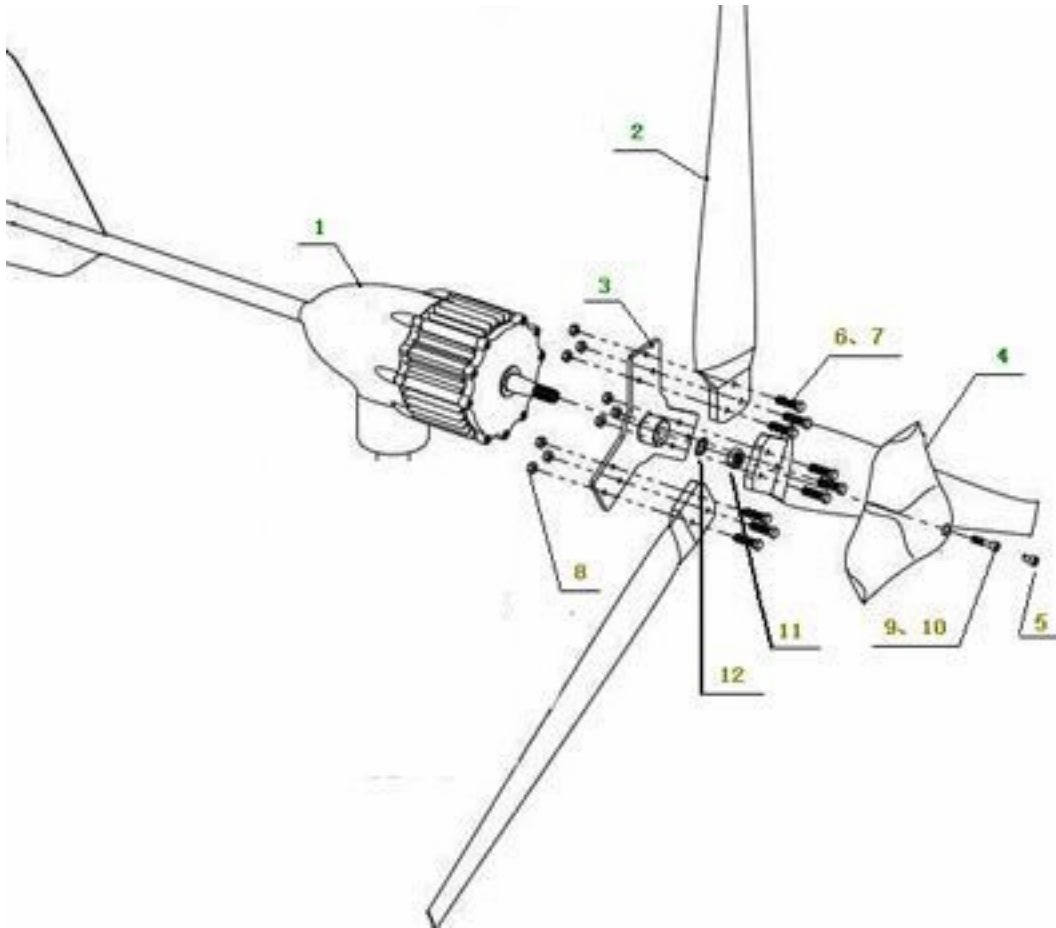

Number	Description	Quantity	Usage
1	Generator Assembly	1	
2	Rotor Blade	3	
3	Rotor Hub	1	
4	Front Cover	1	
5	Front Cover Stopper	1	Fittings
6	Bolt M8*30	9	Rotor blades
7	Flat washer M8	9	
8	Nylock Nut M8	9	
9	Bolt M6*35	1	Front Cover
10	Flat washer M6	1	
11	Nut M16*1.5	1	Generator Assembly
12	Lock Washer M16	1	

2.1 Mounting the rotor hub

1. Remove the nut lock washer and flat washer from the alternator shaft;
2. Slide the rotor hub onto the alternator shaft and place the flat washer and lock washer;

3. Thread and tighten the nut. The nut should be tightened to 70-85 Nm.

2.2 Mounting rotor blades

1. Blades are in front of the rotor hub with the flat side facing upwind.
2. Insert three bolts in holes on the hub and blade. Place flat washers on the end of bolts, thread and tighten nylock self-locking nut. Nuts should be tightened to 8-12 Nm.

2.3 Attaching the spinner

Place the spinner over the center of the hub. Thread the M6*35bolt with lock washer and flat washer into the screw hole on the alternator shaft and tighten by hex key.

2.4 Mounting the yaw pole

Slide the yaw pole onto the yaw shaft of the head assembly and fastened by four bolts M8/15 with flat washers and lock washers.

1. Drill through the tower tube to the electric wire



2. Attach the wind turbine head assembly.



3. Assemble the wind turbine rotor hub



4. Attach the wind turbine rotor blades



5. Attach the wind turbine front cover



6. Secure the wind turbine screw cover



3 Siting



Siting is an important but complicated issue for wind power installation. Consulting a wind energy specialist is recommended if the user is not familiar with wind systems. Four general rules are listed as below for consideration:

- 1 There are two basic requirements for a good site: high average wind speed and low wind turbulence. The higher the average wind speed, the more the power will WINDMAX-H wind turbine generate. The power available in the wind goes up with the cube of the wind speed. For example, the power available in the wind of 5mps speed is nearly twice as of 4mps. The lower the wind turbulence, the lower the stress the wind turbine will have to endure. Lower turbulence also results in more power .The zone with high wind speed but high turbulence is not a desirable site.
- 2 Install the wind turbine as high as you can. The higher the tower, the higher the wind speed and the lower the turbulence .The recommended tower height for the WINDMAX-H is 8 m above ground level without barriers.
- 3 Barriers (trees, buildings, etc.) to the flow of wind will produce wakes that may extend far downwind of the barrier and to a height considerably above the barrier. These wakes are areas decreased wind speed and potentially damaging turbulence.

Two rules of thumb:

- a. A tower immediately downwind of a building should be at least twice of the height of the building.
 - b. A tower should be at least 6 m higher than the highest barrier within 150m radius.
4. The local and national codes and requirements should be complied with.

4. Tower Recommendations

The WINDMAX-H is designed to withstand a maximum horizontal direction force of 500N mounted on the tower. The tower must be capable of withstanding the wind load. A guyed steel pipe tower is the most economical method to install a turbine. 1 ½ inch or 2 inch SCH 40 steel pipe is recommended for the WINDMAX-H guyed tower. The tower should be properly electrically grounded.

Suitable Foundation:

The Construction Method for the tower base is according to the soil conditions at your tower site.

If the tower site is located on solid rock, it just needs to level off.

If the tower site is located on the soft soil, the ground of 0.8m in diameter must need to tamp and it can prevent the foundation from caving in.

If the tower site is located on the loose sand, it needs to dig a hole 0.8m in diameter and 1.5m deep, and then bury a clay pan 60cm deep and tamp the clay pan, and cover concrete of 20cm deep on the clay pan. Once the concrete has set it should be buried before use.

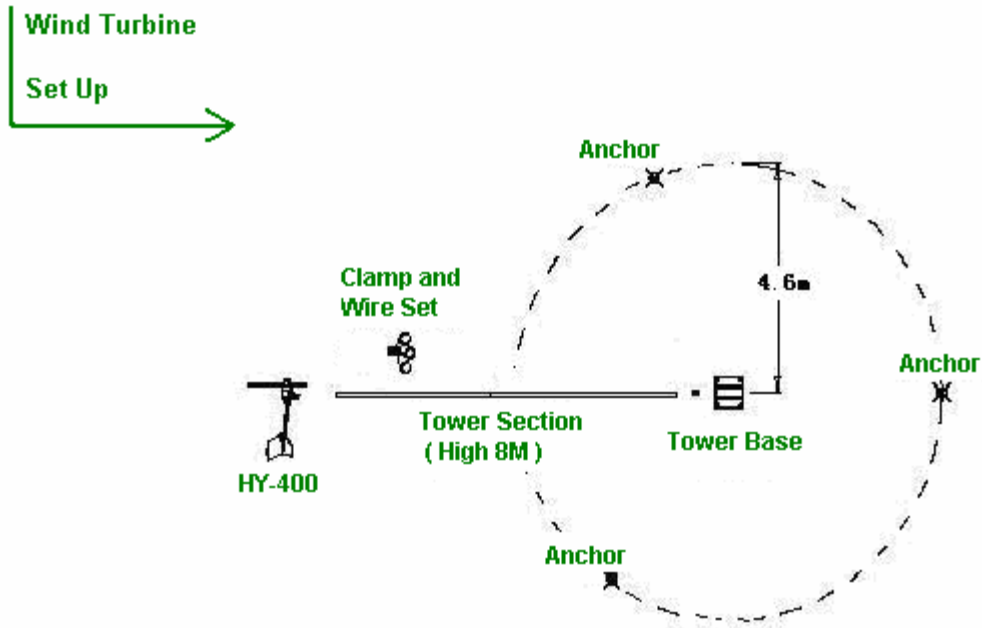

Construction Specification Layout of Tower for Wind Turbine-Guyed Tower

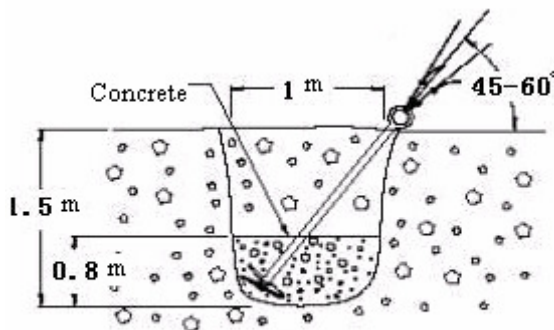

Construction Drawing of Tower Base

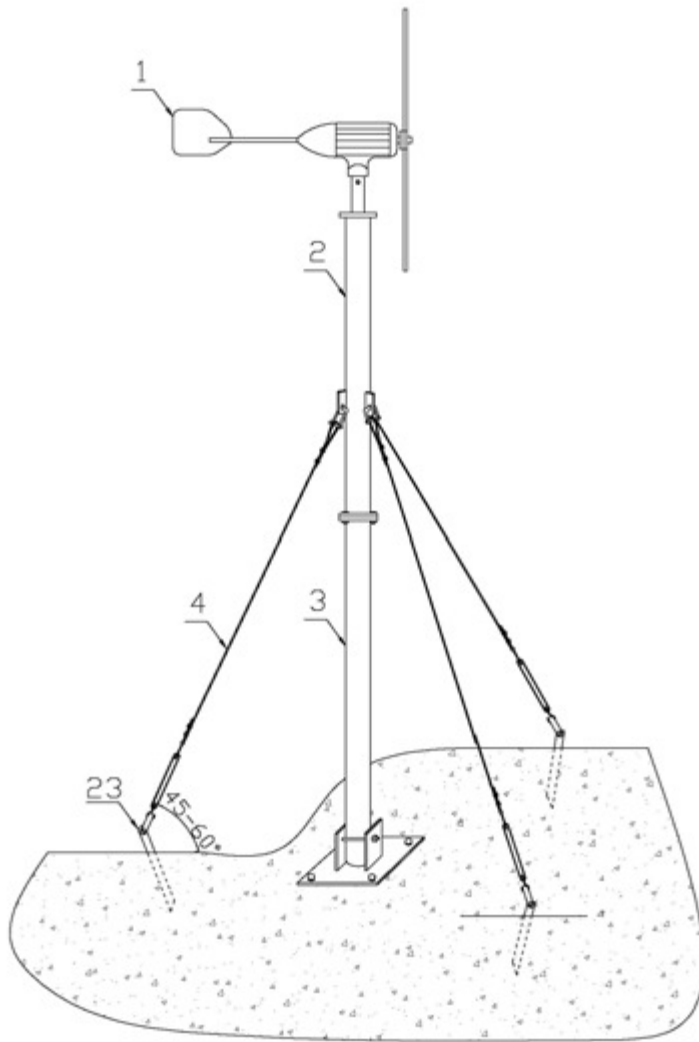

The tower base pad layout

Recommended Tower Specifications

Height of Tower	Diameter Windmax-H5	Diameter Windmax H8	Wall Thickness	Radius of Guy Wire
8 Meter	80 mm	100 mm	3.5 mm	4.6 M
6 Meter	60 mm	80 mm	3.5 mm	4 M
Dimension of Tower Base	800 mm x 800mm x 200 mm			

5. Cable Wiring

The basic wiring diagram of single WINDMAX-H system is as shown.

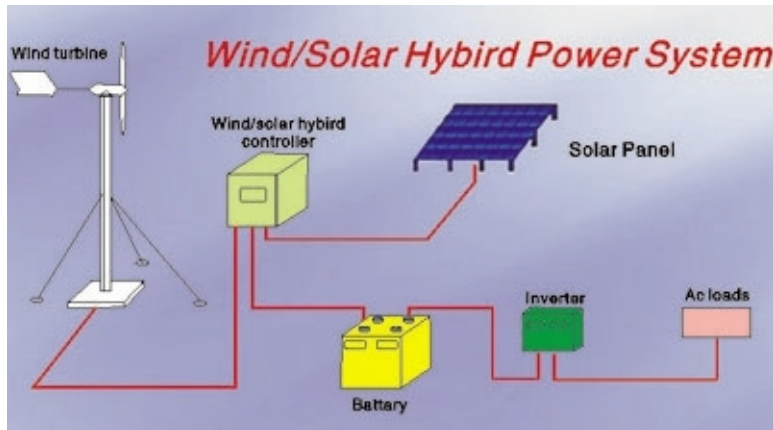

1. **Regulator Connection:** Before erecting the WINDMAX-H tower, connect the WINDMAX-H to the regulator, and turn the breaker switch on the regulator to the closed position. After erecting, make sure that batteries are connected tightly and correctly with the regulator, and then turn the breaker switch to open position.
2. The electric circuit breaker on the regulator protects the batteries in case of accidental shorts.
3. WINDMAX-H system supplied with solar & wind hybrid controller.
4. The battery capacity is subject to client's requirement, but a 100-150AH/12V battery is recommended for a single WINDMAX-H System.
5. Undersized cables will cause energy loss (voltage drop) to the system. The larger the cable size, the smaller the energy loss. However, larger size cables will be more costly.
6. The negative pole of the battery should be properly grounded.

The following cable sizes are recommended for the WINDMAX-H system:

Distance from WINDMAX to battery (meter)	< 50	50-100	100-150
Cable Size (mm ²)	4	6	10

6. Maintenance

The WINDMAX-H is a very reliable set and is designed to run for long periods at severe conditions without any maintenance. But routine checking of system tower and cable wiring system is suggested to maintain the reliability and performance of the system.

1. Check guy rope tension and tighten if needed, especially after storms. During first three months after erecting the tower, periodic inspection should be carried out.
2. Check all electrical connections to make sure they are properly connected, tightened and free from corrosion.

- Maintain batteries according to battery manual.

7. Safety Precautions

The WINDMAX-H is designed with your personal safety as the first priority. However, there are still some inherent dangers involved in the electrical/mechanical equipment.

Safety must be the priority concern during installation of the system.

7.1 Choose a calm day to erect the tower.

7.2 Undersized wires or bad connections should be avoided as they will often result in overheating and potentially cause electrical fire.

7.3 Never approach an operating turbine during strong winds or during thunderstorms.

8. Technical specifications

Model	WINDMAX-H5
Rotor diameter	1.4m (4.6 Feet)
Start up wind speed	2.3m/s or 5.2 mph
Cut-in wind speed	3.0 m/s or 6.7 mph
Rated Outputs	485W @ 13 m/s or 29 mph, 450W @ 26 mph
Survival wind speed	60 m/s or 134 mph
Solar energy input	12V _{DC} , 300W
Battery Voltage	12V _{DC} (24V _{dc} available upon request)

Model	WINDMAX-H8
Rotor diameter	1.8m (5.9 Feet)
Start up wind speed	2.3m/s or 5.2 mph
Cut-in wind speed	3.0 m/s or 6.7 mph
Rated Outputs	775W @ 12.5 m/s or 28 mph, 750W @ 26 mph
Survival wind speed	60 m/s or 134 mph
Solar energy input	12V _{DC} , 300W
Battery Voltage	24 V _{dc} (48V _{dc} available upon request)

9. Power Curves

WindMax H5 Power Curve

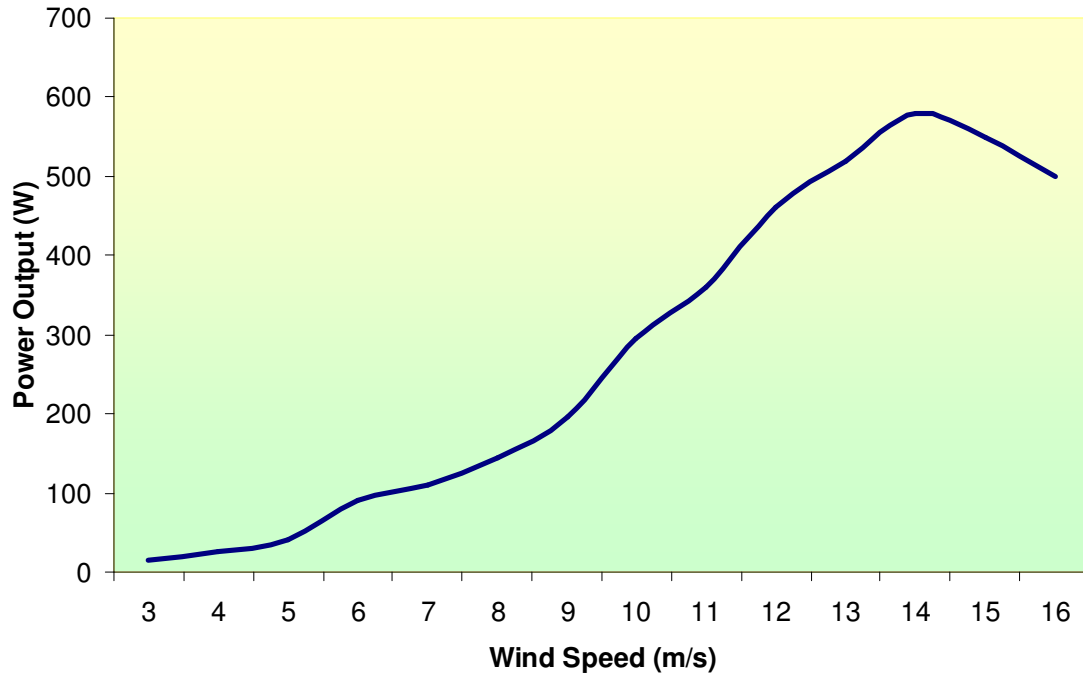

WindMax H8 Power Curve

